

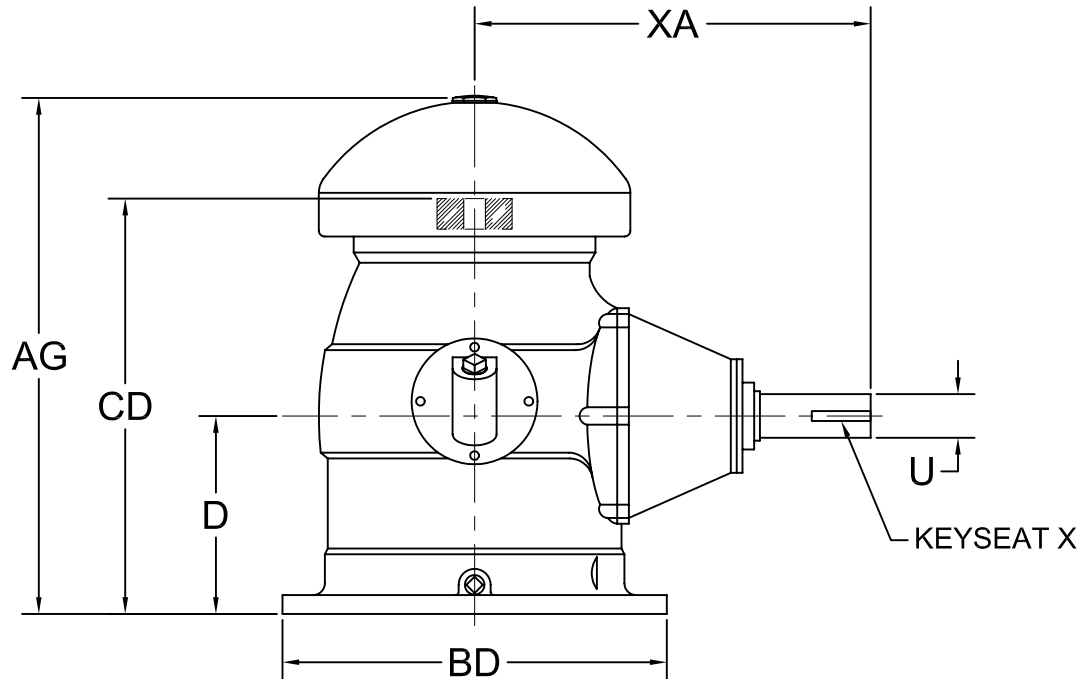

August, 2007

Supersedes all previous issues

RIGHT ANGLE GEAR DRIVE



MODEL	AG	CD	BD	D	XA	U	KEYSEAT X
M40	22.25	17.62	16.50	8.5	17.00	1.88	.38 x .19
M60	22.25	17.62	16.50	8.5	17.00	1.88	.38 x .19
M80	22.25	17.62	16.50	8.5	17.00	1.88	.38 x .19
M100	22.25	17.62	16.50	8.5	17.00	1.88	.38 x .19
M150	26.69	22.62	16.50	11.44	18.00	2.25	.62 x .31
M200	29.94	24.88	16.50	11.44	18.00	2.44	.62 x .31
G250	34.00	29.19	20.00	13.75	21.75	2.94	.75 x .38
G300	34.00	29.19	20.00	13.75	21.75	2.94	.75 x .38
G350	36.00	31.56	20.00	13.75	21.75	2.94	.75 x .38
G400	36.00	31.56	20.00	13.75	21.75	2.94	.75 x .38
G450	37.00	32.75	20.00	13.75	21.75	2.94	.75 x .38
F500	45.44	40.81	24.50	18.75	28.00	3.75	.88 x .44
F590	45.44	40.81	24.50	18.75	28.00	3.75	.88 x .44
F750	45.44	40.81	24.50	18.75	28.00	3.75	.88 x .44

NOTE: MODELS M40 THROUGH M80 AND G40 THROUGH G200A WITH FAN COOLING ONLY, REQUIRE NO OTHER MEANS OF COOLING. THE MODELS M100, M200 AND G250 THORUGH F1500 HAVE COILS INCLUDED AND MUST BE CONNECTED FOR ANY EXTENDED USE OR HIGH AMBIENT CONDITIONS. OIL TEMPERATURES OF 200°F (93°C) ARE NOT DANGEROUS. BEST TEMPERATURE WOULD RANGE BETWEEN 135°F (57°C) AND 180°F (82°C).

NOT FOR CONSTRUCTION, INSTALLATION OR APPLICATION PURPOSES UNLESS CERTIFIED		
CERTIFIED FOR:		
CUSTOMER ORDER NO.:	TAG NO.	
SHOP ORDER:	CERTIFIED BY:	DATE: