

- NOTES :
- 1 DIMENSION BASED ON RANDOLPH GEAR DRIVE. MAY VARY WHEN DRIVER ADAPTOR IS REQUIRED.
  - 2 DIMENSIONS ARE IN INCHES UNLESS OTHERWISE INDICATED.
  - 3 ENGINE TO BASE MOUNTING & COOLING LOOP TO BE FIELD INSTALLED & PLUMBED FOR GEAR COOLING WATER & ENGINE COOLING LOOP PLUMBING RECOMMENDATIONS REFER TO DRAWING NOS. FP-10-04 & FP-10-05.
  - 4 ENGINE OIL & ANTI FREEZE/COOLANT NOT INCLUDED.
  - 5 GEAR SHIPPED FILLED WITH OIL. CHECK LEVEL BEFORE INSTALLATION.
  - 6 SEE DWG ON PAGE 402 FOR RIGHT ANGLE GEAR DIMENSIONS.

125#DISCHARGE FLANGE						
A	DA	DB	DG	DK	DD	
4	7.50	8	.62	1.00	10.00	
6	9.50	8	.75	1.00	10.25	
8	11.75	8	.75	1.12	11.50	
10	14.25	12	.88	1.19	14.00	

250#DISCHARGE FLANGE						
A	DA	DB	DG	DK	DD	
4	7.88	8	.75	1.00	10.00	
6	10.63	12	.75	1.44	10.69	
8	13.00	12	.88	1.63	12.00	
10	15.25	16	1.00	1.88	14.69	

FLOW	MODEL	NO. OF STAGES	B - 1ST STAGE	B - ADD'L STAGE	C	E	F	K	CG	AA
250	FPI0WALC		22.26	7.63	12.25	6.63	11.25	4		
500	FPIICLC		25.26	9.88	13.25	6.25	12.13	6		
750	FPIICHC		25.26	9.88	13.25	6.25	12.13	6		
1000	FPI2CHC		28.26	11.00	13.25	6.25	12.13	6		
1500	FPI4RJHC		30.51	11.50	15.00	9.63	14.00	8		
2000	FPI4RHHC		42.51	13.63	15.00	11.38	13.75	10		
2500	FPI6DMC		52.25	15.25	19.00	16.00	17.50	10		

FLOW	A	DH	HH	AD	G	J	H	MIN SUBM.
250	4	7.00	22.00	1.19	16.00	.63	14.00	23.93
500	6	7.63	25.00	1.19	19.00	.75	17.00	29.25
750	6	7.63	25.00	1.19	19.00	.75	17.00	33.75
1000	6	7.63	25.00	1.19	19.00	.75	17.00	40.25
1500	8	8.75	26.00	1.19	21.00	.75	18.75	51.63
2000	10	10.56	28.25	1.37	25.00	.75	22.75	61.38
2500	10	10.56	28.25	1.37	25.00	.75	22.75	66.00

NOT FOR CONSTRUCTION, INSTALLATION OR APPLICATION PURPOSES UNLESS CERTIFIED.	CERTIFIED FOR:									APPROVAL			UL	FM	ULC			
	CUSTOMER ORDER NO:									IDENTIFICATION NO:						<input type="checkbox"/>	<input type="checkbox"/>	<input type="checkbox"/>
	PUMP DATA	SIZE	NO. OF STAGES	CURVE NO.	GPM	HEAD (PSI)	PUMP MAX BHP	PUMP RPM	FLANGE SIZE #	WEIGHT								
		ENGINE DATA	MAKE	MODEL	USABLE BHP	RPM	VOLTAGE	POLARITY	WEIGHT									
	GEAR DATA	MAKE	MODEL	MAXIMUM BHP	RATIO	WEIGHT												
		BASEPLATE: <input type="checkbox"/> YES <input type="checkbox"/> NO																
	SHOP ORDER:			CERTIFIED BY:			DATE:			TOTAL WEIGHT								

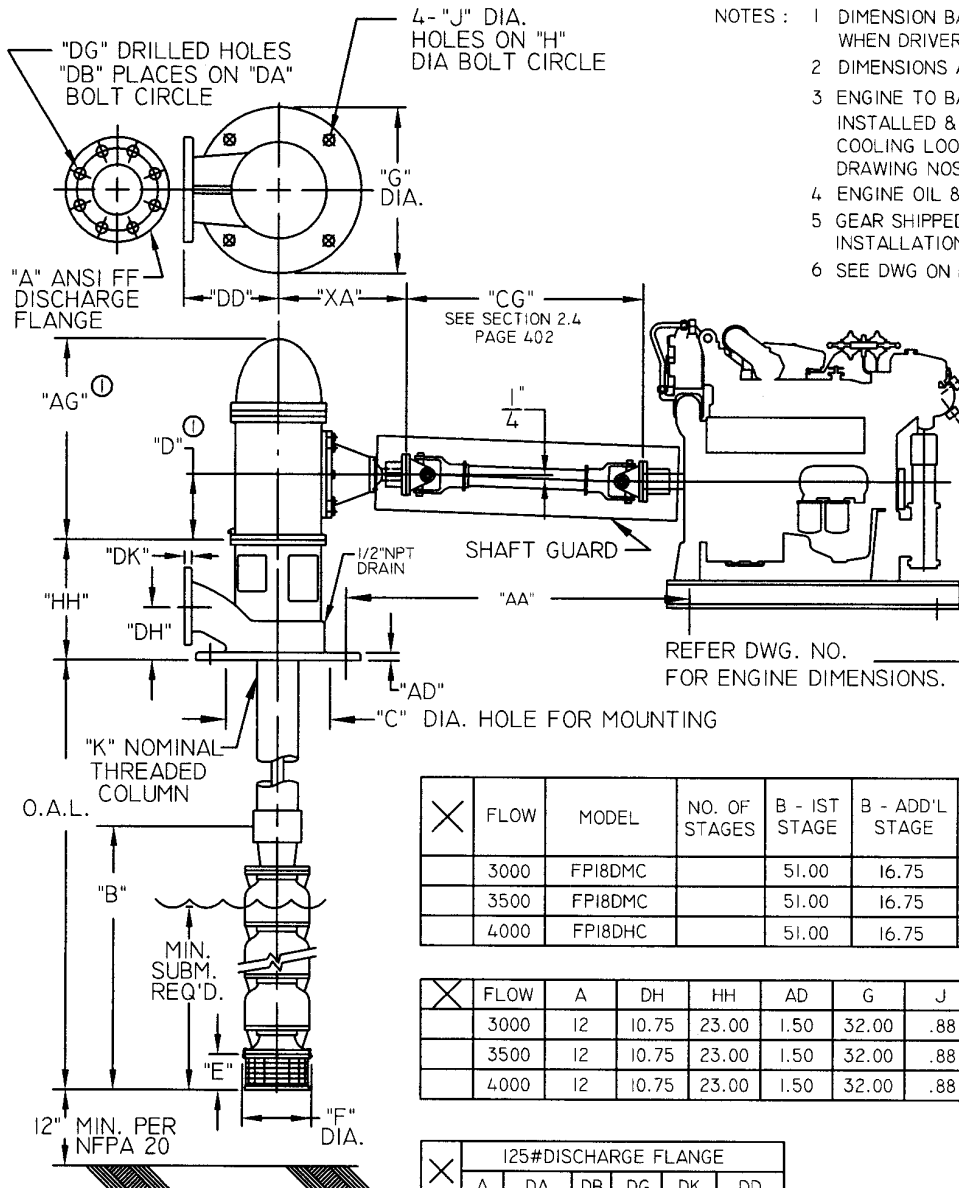

×	FLOW	MODEL	NO. OF STAGES	B - 1ST STAGE	B - ADD'L STAGE	C	E	F	K	CG	AA
	3000	FPI8DMC		51.00	16.75	21.00	16.75	19.50	12		
	3500	FPI8DMC		51.00	16.75	21.00	16.75	19.50	12		
	4000	FPI8DHC		51.00	16.75	21.00	16.75	19.50	12		

×	FLOW	A	DH	HH	AD	G	J	H	MIN SUBM.
	3000	12	10.75	23.00	1.50	32.00	.88	30.00	103.75
	3500	12	10.75	23.00	1.50	32.00	.88	30.00	103.75
	4000	12	10.75	23.00	1.50	32.00	.88	30.00	237.75

×	125# DISCHARGE FLANGE					
	A	DA	DB	DG	DK	DD
	12	17.00	12	.88	1.25	16.00

NOT FOR CONSTRUCTION, INSTALLATION OR APPLICATION PURPOSES UNLESS CERTIFIED.	CERTIFIED FOR:										APPROVAL			UL	FM	ULC			
	CUSTOMER ORDER NO:										IDENTIFICATION NO:						<input type="checkbox"/>	<input type="checkbox"/>	<input type="checkbox"/>
	PUMP DATA	SIZE	NO. OF STAGES	CURVE NO.	GPM	HEAD (PSI)	PUMP MAX BHP	PUMP RPM	FLANGE SIZE #	WEIGHT									
		MAKE		MODEL		USABLE BHP	RPM	VOLTAGE	POLARITY	WEIGHT									
	GEAR DATA	MAKE		MODEL		MAXIMUM BHP		RATIO		WEIGHT									
		BASEPLATE: <input type="checkbox"/> YES <input type="checkbox"/> NO																	
SHOP ORDER:			CERTIFIED BY:			DATE:			TOTAL WEIGHT										



August 2002

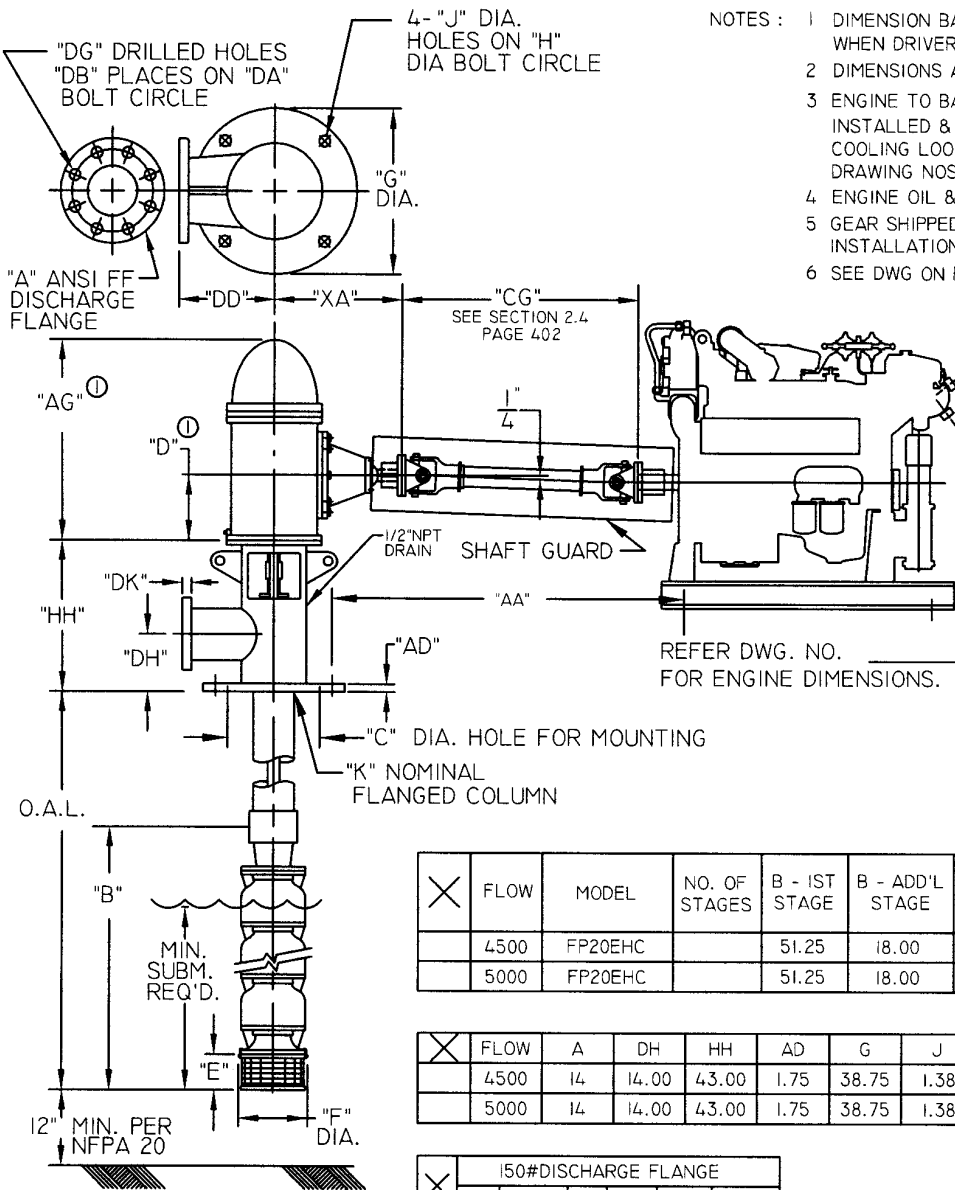

- NOTES :
- 1 DIMENSION BASED ON RANDOLPH GEAR DRIVE. MAY VARY WHEN DRIVER ADAPTOR IS REQUIRED.
  - 2 DIMENSIONS ARE IN INCHES UNLESS OTHERWISE INDICATED.
  - 3 ENGINE TO BASE MOUNTING & COOLING LOOP TO BE FIELD INSTALLED & PLUMBED FOR GEAR COOLING WATER & ENGINE COOLING LOOP PLUMBING RECOMMENDATIONS REFER TO DRAWING NOS. FP-10-04 & FP-10-05.
  - 4 ENGINE OIL & ANTI FREEZE/COOLANT NOT INCLUDED.
  - 5 GEAR SHIPPED FILLED WITH OIL. CHECK LEVEL BEFORE INSTALLATION.
  - 6 SEE DWG ON PAGE 402 FOR RIGHT ANGLE GEAR DIMENSIONS.

×	FLOW	MODEL	NO. OF STAGES	B - 1ST STAGE	B - ADD'L STAGE	C	E	F	K	CG	AA
	4500	FP20EHC		51.25	18.00	26.00	20.75	24.13	14		
	5000	FP20EHC		51.25	18.00	26.00	20.75	24.13	14		

×	FLOW	A	DH	HH	AD	G	J	H	MIN SUBM.
	4500	14	14.00	43.00	1.75	38.75	1.38	36.00	91.75
	5000	14	14.00	43.00	1.75	38.75	1.38	36.00	91.75

×	150#DISCHARGE FLANGE					
	A	DA	DB	DG	DK	DD
	14	18.75	12	1.13	1.38	22.00

NOT FOR CONSTRUCTION, INSTALLATION OR APPLICATION PURPOSES UNLESS CERTIFIED.	CERTIFIED FOR: _____ APPROVAL <input type="checkbox"/> UL <input type="checkbox"/> FM <input type="checkbox"/> ULC										
	CUSTOMER ORDER NO: _____					IDENTIFICATION NO: _____					
	PUMP DATA	SIZE	NO. OF STAGES	CURVE NO.	GPM	HEAD (PSI)	PUMP MAX BHP	PUMP RPM	FLANGE SIZE #	WEIGHT	
	ENGINE DATA	MAKE		MODEL		USABLE BHP	RPM	VOLTAGE	POLARITY	WEIGHT	
	GEAR DATA	MAKE		MODEL		MAXIMUM BHP		RATIO		WEIGHT	
	BASEPLATE: <input type="checkbox"/> YES <input type="checkbox"/> NO										
	SHOP ORDER:			CERTIFIED BY:			DATE:		TOTAL WEIGHT		