

**CASING RELIEF VALVE**

**Size** 3/4" Threaded  
**Temperature Range** Water, Air: to 180°F Max.  
**Materials**  
 Body & Cover: Cast Bronze ASTM B62  
 Stainless Steel ASTM A743-CF-16Fa  
 Trim: Brass & Stainless Steel 303  
 Rubber: Buna-N® Synthetic Rubber

**Flow Range: < 2500 GPM**

UL Listed 55L Range psi	Approximate Increase for Each Clockwise Turn of Adjusting Screw
20 to 175	28.0 psi

FM Approved 55L Range psi	Approximate Increase for Each Clockwise Turn of Adjusting Screw
0 to 75	8.5 psi
20 to 200	28.0 psi
100 to 300	18.0 psi

**Pressure Ratings** Cast Bronze 400 psi Max.  
 Stainless Steel 400 psi Max.

**Adjustment Ranges** 0 to 75 psi  
 20 to 200 psi  
 100 to 300 psi

**WEIGHT = 6 LBS**

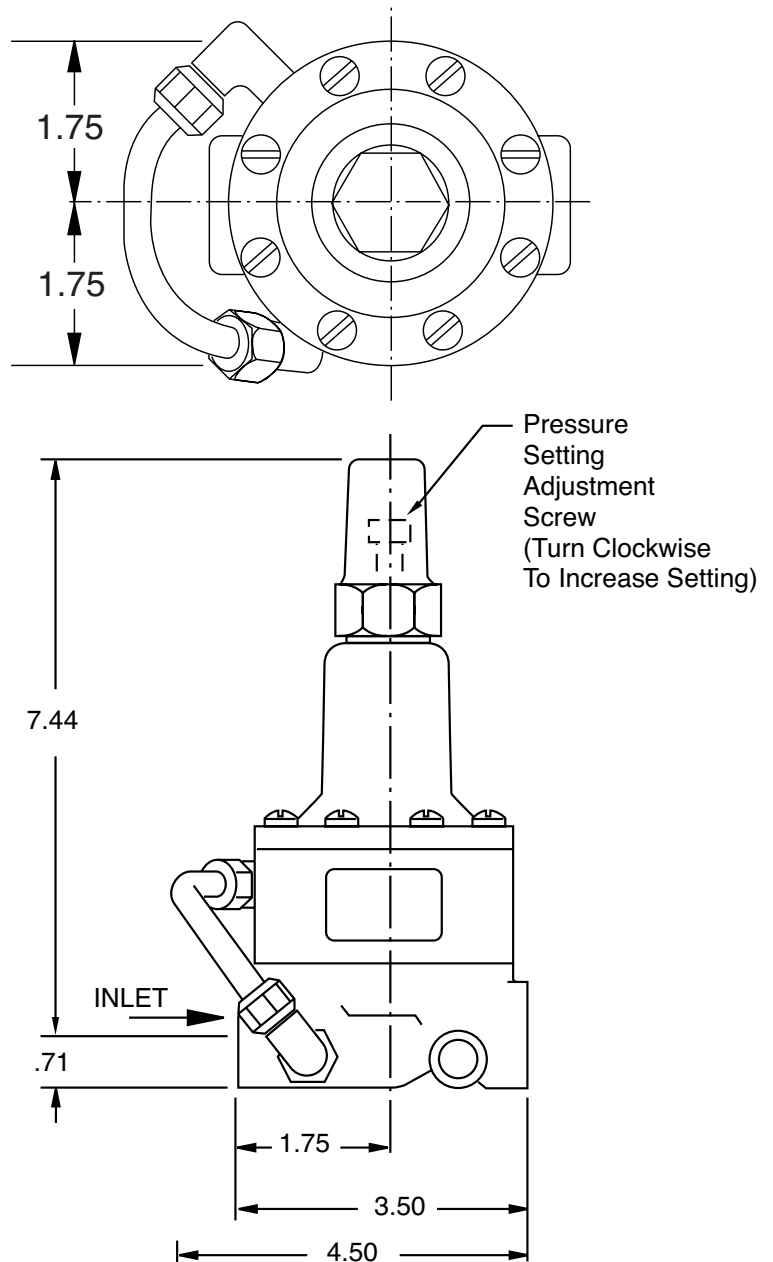

<b>NOT FOR CONSTRUCTION, INSTALLATION OR APPLICATION PURPOSES UNLESS CERTIFIED</b>		
CERTIFIED FOR:		
CUSTOMER ORDER NO.:	TAG NO.	
SHOP ORDER:	CERTIFIED BY:	DATE: