

13D HOME DEFENDER

CAPACITY 30, 40, 50, & 60 GPM
PRESSURE 30, 35, 40, 45, 50, & 55 PSI
PUMP WETTED MATERIAL 316L SS
MOTOR HP 1.5, 2, 3, & 5
VOLTAGE 220 VAC
APPROVAL UL448B & UL508A

HP	A	B	C	D	J
1.5	12.00	20.00	27.00	4.25	12.00
2					13.00
3					14.00
5					15.00

ALL DIMENSIONS IN INCHES
DIMENSIONS APPROXIMATED

CONNECTIONS	
E	0.75 FNPT RELIEF VALVE DISCHARGE
F	1.50 FNPT SUCTION
G	0.75 HOSE DRAIN
H	1.50 FNPT DISCHARGE

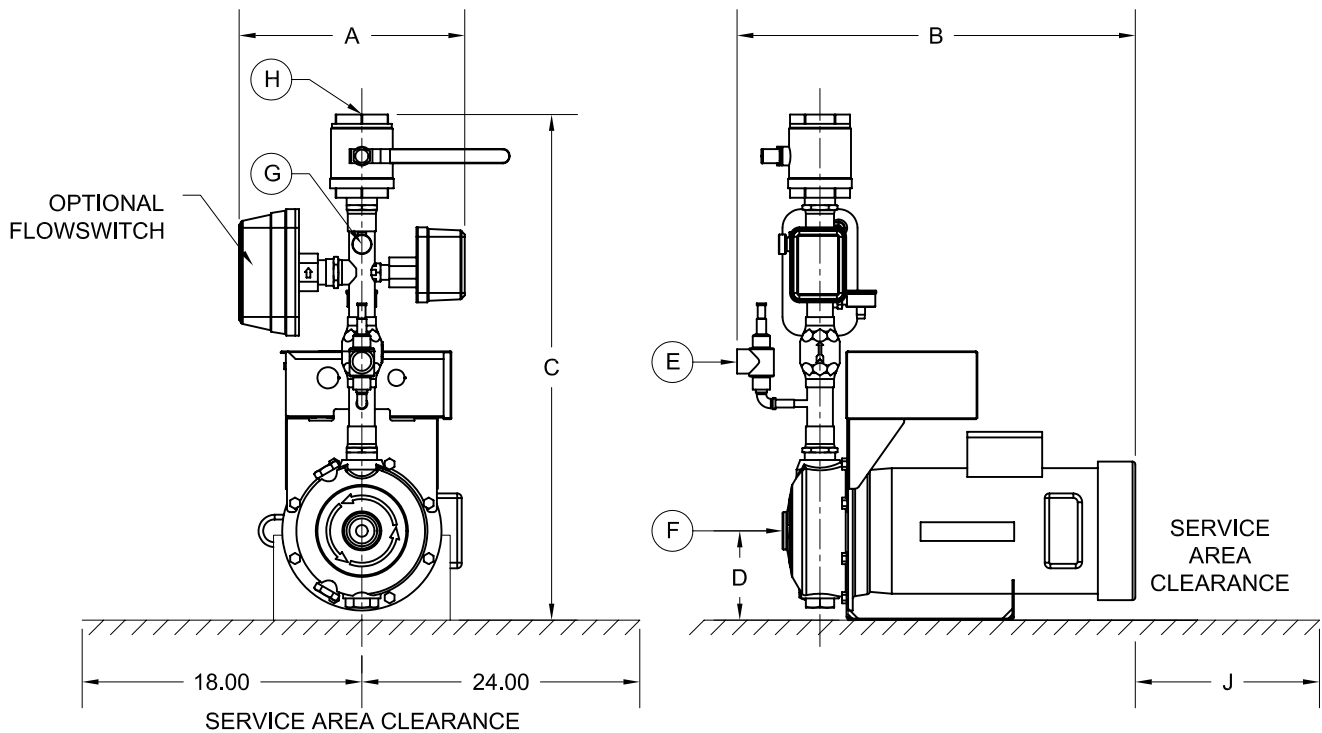

NOT FOR CONSTRUCTION, INSTALLATION OR APPLICATION PURPOSES UNLESS CERTIFIED		
CERTIFIED FOR:		
CUSTOMER ORDER NO.:	TAG NO.	
SHOP ORDER:	CERTIFIED BY:	DATE: